

PERFORMANCE LIMITS OF LOW-TEMPERATURE HEAT PIPES

V. V. Barsukov, L. N. Mishchenko,
and G. F. Smirnov

UDC 536.58

A mathematical relation is shown (in integral as well as in criterial form) for calculating the performance limits of heat pipes. Theoretical results are compared with test data.

Low-temperature heat pipes are widely applicable in heat dissipating and thermostating systems. The available research data on processes which occur in heat pipes are limited, essentially, to those where liquid metals serve as the heat carrier.

The gist of all recommendations for ways to describe the processes in heat pipes is to use the integral equation of mechanical energy balance:

$$\Sigma \Delta P = \Delta P' + \Delta P'' \leq \Delta P_{\sigma} = \Delta P_h. \quad (1)$$

A certain indeterminacy is involved in the calculation of pressure losses during liquid flow through a porous structure, owing to the use of the permeability coefficient K in the Darcy formula and to the tentative choice of the design length (the velocity of liquid and that of vapor change in the evaporation zone and in the condensation zone), which is especially significant in the case of heat pipes with a relatively short adiabatic segment. The error in the calculation of the capillary potential (ΔP_{σ}) according to the Laplace formula is due to some arbitrariness in defining the curvature radii r_e of the evaporator segment and r_c of the condenser segment. Some authors [4, 5] suggest that

$$r_e = \frac{a}{2}; r_c = \infty, \text{ i.e. } \theta = \frac{\pi}{2}.$$

For this reason, a direct experimental verification of the fundamental integral relation (1) for heat pipes under various operating conditions was deemed both necessary and useful.

A performance analysis of low-temperature heat pipes [1, 2, 6] has revealed, along with "hydrodynamic locking" (a limit on power, according to Eq. (1)), also a limit imposed by "locking" in the capillary structure. Other power limiting effects which are typical of heat pipes with liquid metal (gasodynamic locking, separation of the liquid by a vapor stream, etc.) may, as a rule, be disregarded in the case of low-temperature heat pipes.

Apparently, the fundamental equation for low-temperature heat pipes must allow for both limiting factors. We assume, then, that:

1. The pipe begins to steam when the liquid inside the structure boils, and this occurs at a definite temperature difference between the pipe wall and the vapor (ΔT_{lim}).
2. The heat is transmitted through the structure by equivalent conduction (λ_{eq}).
3. The operating temperature range and the power of the heat pipe are given.

We now develop Eq. (1) in terms of Darcy's Law for the flow of liquid through a capillary structure and we assume the flow of vapor to be laminar so that, with the lengths of the heat input and output zones determined from the conditions of heat transfer, we obtain after a few transformations:

Translated from *Inzhenerno-Fizicheskii Zhurnal*, Vol. 25, No. 2, pp. 249-253, August, 1973. Original article submitted February 8, 1973.

© 1975 Plenum Publishing Corporation, 227 West 17th Street, New York, N.Y. 10011. No part of this publication may be reproduced, stored in a retrieval system, or transmitted, in any form or by any means, electronic, mechanical, photocopying, microfilming, recording or otherwise, without written permission of the publisher. A copy of this article is available from the publisher for \$15.00.

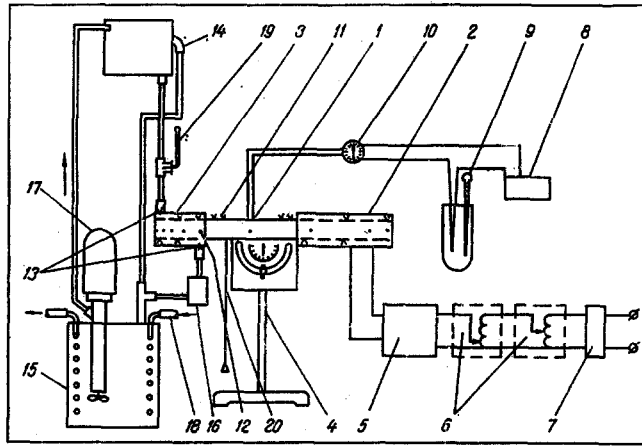

Fig. 1. Schematic diagram of the test apparatus; 1) heat pipe; 2) heater; 3) calorimeter; 4) stand; 5) model K-50 instrument assembly; 6) laboratory autotransformers; 7) voltage stabilizer; 8) potentiometer; 9) Dewar flask; 10) switch; 11) thermocouples in the sheath of a heat pipe; 12) thermocouples in the vapor channel of a heat pipe; 13) differential thermocouple (inlet-outlet for cooling water); 14) pressure tank; 15) thermostat; 16) automatic instrument for measuring the flow rate; 17) pump; 18) thermostat circuit for the cooling water; 19) mercury thermometer; 20) plumb.

TABLE 1. Characteristic Dimensions

Criteria group	Characteristic dimension
We	$\sqrt{l_0 a}$
Re''	d_v
Ga''	\sqrt{K}
Re'	
Ga'	

where

$$\left[l_0 - \frac{Q \ln(1-x)}{4\pi\lambda_{eq}} \sum \frac{1}{\Delta t_i} \right] c d_w + \frac{1}{4} \gamma' \sin \varphi \frac{Q}{\Delta i \pi d_{in}^2} \times \left[\frac{32v''}{d_{in}^2 (1-x)^4} + \frac{v'}{\Pi d_w^2 [1-(1-x)^2]} \right], \quad (2)$$

$$x = \frac{2\delta_c}{d_{in}}; \quad c = \frac{a}{d_w}; \quad \Pi = \frac{c_c \epsilon^3}{16(1-\epsilon^2)}$$

Equation (2) combines the two basic limitations on the performance of low-temperature heat pipes and is subject to experimental verification.

With the aid of some very simple algebraic transformations, Eq. (2) can easily be reduced to the criterial form*

$$\frac{We \cos \theta}{1 + 0.5(B_e + B_c)} + 0.25 \sin \varphi \geq \frac{8Re''}{Ga''} \cdot \frac{\rho''}{\rho'} + 0.25 \frac{Re'}{Ga'}; \quad (3)$$

where

$$B_e = \frac{Q |\ln(1-x)|}{2\pi\lambda_{eq} \Delta t_e l_0}; \quad B_c = \frac{Q |\ln(1-x)|}{2\pi\lambda_{eq} \Delta t_c l_0}$$

It is quite evident that complexes B_e and B_c represent the ratios of evaporator length and condenser length, respectively, to the transport distance (adiabatic segment). It must be noted that the criterial groups in Eq. (3) have been referred to different characteristic dimensions (Table 1). These different choices are dictated by the contributions of various independent processes (evaporation, condensation, transport of liquid, etc.) to the operating mechanism of a heat pipe, making it feasible to analyze the similarity of pipes on the basis of analogies between component processes.

*This criterial form is valid for heat pipes with $l_0 \neq 0$.

TABLE 2. Characteristics of the Tested Heat Pipes

Pipe No.	Sheath material	Wick material	Heat carrier	l_e, m	l_b, m	l_c, m	$d_{out}, m \cdot 10^3$	$d_{in}, m \cdot 10^2$	$d_{vc}, m \cdot 10^3$	$d_w, m \cdot 10^5$	$a, m \cdot 10^5$	n
1	Copper	Brass	Ethyl alcohol	0,20	0,185	0,10	1,8	1,6	1,5	7,0	10,0	3,5
2	Copper	Copper	Ethyl alcohol	0,10	0,25	0,10	1,2	0,9	0,74	5,5	8,0	6

Formally, however, it is not difficult to introduce a single characteristic dimension. Equation (3) will then be augmented with appropriate geometrical ratios.

With the aid of Eq. (3), it becomes possible to generalize the test data pertaining to heat pipes whose geometries and thermophysical properties differ. The characteristics of the test pipes are listed in Table 2. The test apparatus is shown schematically in Fig. 1. The evaporator segment of a heat pipe was heated with an electric heater 2. The power of this heater was measured with a model K-50 instrument 5. The heater power was regulated smoothly through laboratory autotransformers 6. The heat was collected in a tubular calorimeter 3. The power output was measured at a fixed flow rate of cooling water (indicated by an automatic instrument 16 for measuring the flow rate) and a fixed temperature drop from inlet to outlet (indicated by a differential thermocouple 13). Furthermore, during the experiment were also measured the temperature distribution in the sheath and in the vapor channel of the heat pipe (with thermocouples 11 and 12 respectively) as well as the temperature of the cooling water. Temperature fluctuations at the water inlet did not exceed 0.5°C.

The test data pertaining to the power limit of heat pipe No. 1 (Table 2) are compared in Fig. 2 with calculations.

In the experiment we varied the inclination of the heat pipe to the horizontal, which affected the available hydrostatic head and thus accordingly also the power limit of the heat pipe.

The power limit was indicated by a sharp rise in the temperature of the pipe wall at the endface of the evaporator segment, which corresponded to the condition of hydrodynamic locking.

The power limit was calculated by solving Eq. (2) with respect to Q.

It seems that the results of this comparison confirm the suitability of the integral relation (1) for determining the performance limits of low-temperature heat pipes.

The test data evaluated in criterial form are shown in Fig. 3.

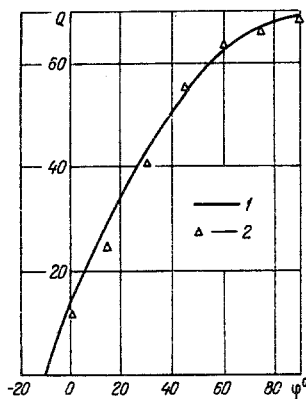

Fig. 2

Fig. 2. Power limit of a heat pipe as a function of the inclination angle: 1) calculated relation; 2) test values.

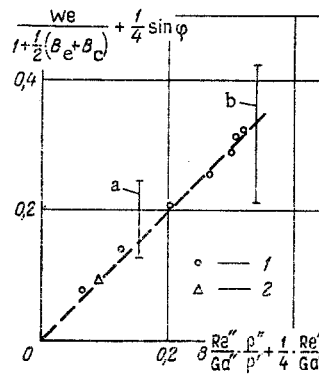

Fig. 3

Fig. 3. Performance limits of heat pipes, in dimensionless coordinates: 1) heat pipe No. 1; 2) heat pipe No. 2; a) according to data in [7]; b) according to data in [8].

In all test pipes the resistance to vapor flow through the evaporator channel ($\Delta P''$) was a negligibly small part of the total resistance ($\Sigma \Delta P$). It is to be noted that the design length assumed for the condensate transport through the structure (of the relatively short adiabatic segments) has a large effect on the data evaluation [7, 8]. For this reason, we consider here the extreme cases:

$$l = l_0 + 0.5(l_e + l_c); \quad l = l_0 + l_e + l_c.$$

From an analysis of calculations and test values, as shown here, one may conclude that formulas (2) and (3) are appropriate for the design of heat pipes and for an evaluation of their essential performance characteristics.

NOTATION

P	is the pressure;
r	is the radius of the meniscus curvature;
a	is the size of a cell in the wick mesh;
θ	is the critical wetting angle;
K	is the permeability coefficient;
t	is the temperature;
σ	is coefficient of surface tension;
l	is the length;
λ	is the thermal conductivity;
Q	is the power;
d	is the diameter;
φ	is the angle of pipe inclination;
ν	is the kinematic viscosity;
ρ	is the density;
ϵ	is the porosity;
c_c	is the form factor;
δ	is the thickness;
Δi	is the heat of evaporation;
γ	is the specific gravity;
n	is the number of mesh layers in the wick.

Subscripts and Superscripts

σ	refers to capillary;
e	refers to evaporator segment;
c	refers to condenser segment;
lim	refers to limit;
w	refers to wire;
f	refers to wick;
in	refers to internal;
eq	refers to equivalent;
o	refers to adiabatic segment;
v	refers to vapor channel;
out	refers to external;
h	refers to hydrostatic;
(')	refers to liquid phase;
('')	refers to vapor phase.

LITERATURE CITED

1. L. L. Vasil'ev and S. V. Konev, in: Heat and Mass Transfer at Low Temperatures [in Russian], Izd. Nauka i Tekhnika, Minsk (1970).
2. Z. R. Gorbis, G. F. Smirnov, and L. N. Mishchenko, in: Refrigeration Engineering and Technology, No. 12 [in Russian], Izd. Tekhnika, Kiev (1971).
3. G. F. Smirnov and L. N. Mishchenko, Proc. Fourth All-Union Confer. on Heat and Mass Transfer, Vol. 2, Part 2, Minsk (1972).
4. K. Moritz and R. Pruschek, Chemie-Ingenieur Technik, 41, Nos. 1-2, 30-37 (1969).

5. D. M. Ernst, Second Internatl. Confer. on Thermoelectric Power Generation, Stresa, Italy.
6. A. Bahz, E. Burck, and W. Hufschmidt, Second Internatl. Confer. on Thermoelectric Power Generation, Stresa, Italy.
7. P. I. Marto and W. L. Mosteller, ASME Paper No. HT-24 (1969).
8. W. C. Fackler and J. M. Trummel, AIAA Paper No. 419 (1971).